

5.0 GENERAL WALL AND CEILING INSTALLATION

This section covers the installation of GIB® plasterboard in walls and ceilings. Installation guidance is also provided for speciality systems; GIB EzyBrace® and GIB Aqualine® Wet Area Systems.

For further installation guidance including system specifications for other speciality GIB® systems refer to the appropriate system literature at gib.co.nz

5.1 BEFORE STARTING INSTALLATION

Inspect the framing

Check that the surface is flat and that there is nothing that could affect the finished surface. For example:

Nogs not flush.



Nails not below the framing surface.



Do not simply rely on the building inspector at the pre-line inspection but take responsibility and understand the effects of framing moisture on content and the quality of finish.

Moisture content to be 18% or less.

Moisture loss in timber framing can lead to screw pops and/or joint cracks.



Nail plates or hold down ties not checked in flush with the surface insulation bulging out between studs.



These are all factors that will affect the quality of the finished surface. **The time to correct them is now.** Once fixing commences it indicates an acceptance of the substrate quality.

It is the responsibility of the framing contractor to provide a substrate that allows the plasterboard fixer to effectively install the plasterboard in accordance with the manufacturer's instructions.

Likewise it is the responsibility of the plasterboard fixer to provide a suitable surface for the plasterboard stopper to effectively carry out the stopping process.

There is no place in the industry for the phrase "The stopper will fix it".

All trades involved in the process have to take full responsibility for the quality of their workmanship.

Tip: For easier installation it is recommended to install the plasterboard ceiling before lining the walls.

Cutting GIB® Plasterboard

Measure the wall to determine the required sheet size. Generally cut the sheet 2mm–3mm less than the exact dimension needed.

Position the sheet with the face paper side up. Mark the sheet as required.

Firmly hold the straight edge on the line to be cut.

Cut through the face paper and into the plaster core by sliding the knife blade against the straight edge.

Break the sheet core by snapping the sheet back firmly while holding on to the sheet edge.

Turn the sheet over so that back paper is now facing up. Score the back paper to complete the cut.



Scan to view GIB® installation videos



Cutting GIB® Plasterboard

For sheets requiring multiple cuts, use a handsaw to complete the short cuts before scoring and snapping the longer cut.



Mark the position of any power outlets or pipes on the face of the board.

Make hole at a corner of the marked outlet. Cut out the box as marked.

Tip: To get the saw started, drill holes at each of the corners but within the opening. In some cases the saw can simply be pushed through the sheet without the need for holes.



Fixing GIB® Plasterboard

Apply GIBFix® adhesive at specified centres. Apply immediately prior to fixing the GIB® plasterboard. Do not allow time for the adhesive to “skin” over.

GIBFix® adhesive daubs should be approximately 35mm in diameter and about 12mm high.

Cold temperatures (10°C or less) will affect the curing time of adhesive. It is recommended that steps are taken to achieve 10°C at the time of installation.

Tip: Do not place GIBFix® adhesive behind fasteners. This will increase the risk of “fastener popping”. Place at least 200mm from fasteners

Fit the GIB® plasterboard in position against the framing. Press the sheet firmly against the framing to ensure a good bond with the adhesive.

Sheets must be 5–10mm from the floor. Place packers to suit OR use a flat bar to lift the sheet off the floor.

(Note that some specific fire rated systems require that the sheets are fixed hard to the floor).

Install fasteners at specified centres. Make sure that the head of the fastener is bedded just below the surface of the board.

Tip: Use an electric drywall screw gun equipped with an adjustable depth control head and Phillips bit. If a screw is overdriven and the paper and/or core of the GIB® plasterboard is damaged, insert a second screw approximately 50mm from the first and then remove the first screw.



Temporary Fixing

Temporary direct fix screws through blocks

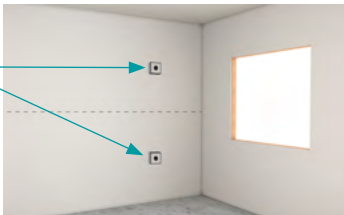

Tip: Occasionally a bow may develop in the board due to storage methods. It might be necessary to temporarily hold the board until the adhesive cures.

Screw through an offset of plasterboard and remove the block and screw once adhesive has cured.

Joint Placement

Give careful consideration to the placement of sheet joints in walls and ceilings.

Try to minimise sheet joints by using the largest sheet size available.

Where possible place joints in situations where they are less likely to be affected by critical lighting.

Horizontal Fixing

Sheet edge joints in horizontally fixed walls may be unsupported (stud centres must not exceed 600mm).

For levels of finish 3 and 4, sheet end butt joints may be made on studs. However, to reduce the risk of joint defects, it is strongly recommended that sheet end butt joints are back blocked off framing.

Vertical Fixing

Form sheet edge joints in vertically fixed walls on studs.

Shorter vertical joints (400mm or less) such as above a window or door can be made off the stud. Joints under windows can be made off the stud provided that nogs are installed to reduce the unsupported joint to 600mm or less. Alternatively the joint may be back blocked.

Around Door or Window Openings

Sheet edge joints formed at the edge of door and window openings are highly prone to cracking. To reduce the risk of cracking it is strongly recommended that sheets are cut around openings and joints are formed no closer than 200mm to the edge of the opening.

General Installation – Not recommended

Prone to cracking due to frame flexibility. Not recommended for general installations.

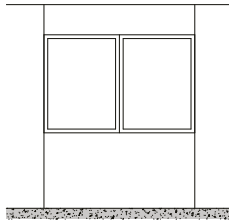

General Installation – Not recommended

Time consuming for no real benefit. Still highly prone to cracking.

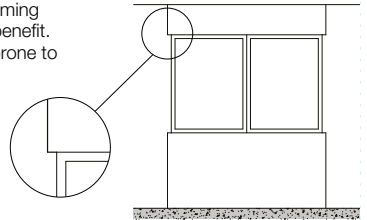

General Installation – Acceptable

This moves the joint away from problem area. Floating joint, correctly taped and stopped is less likely to crack.

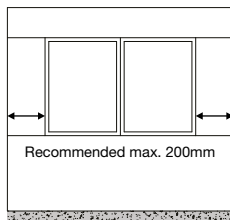

General Installation – Acceptable

Positioning the joint 200mm from the window edge will reduce the likelihood of cracking.

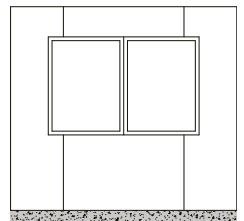

General Installation – Recommended

If the grooved jambs have been accurately installed, this is not difficult for a competent fixer. The lining on this wall will need to be fixed prior to any adjacent walls.

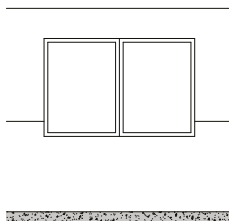

High Movement Applications

For applications prone to a high degree of movement, such as transportable homes, consideration should be given to installing a control joint at the edges of the door or window. (see p.52)

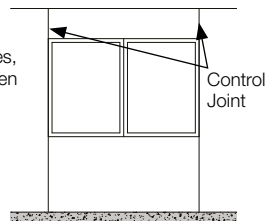

5.3 GIB® PLASTERBOARD INSTALLATION – WALLS

For installation guidance on GIB EzyBrace® and GIB Aqualine® Wet Area Systems refer to the GIB® Performance Systems section.

For all other GIB® Performance Systems refer to the relevant GIB® Systems literature.

5.3.1 Timber Frame – Horizontally Fixed

Wall Framing

- Framing dimensions, spacings and nog requirements must comply with NZS3604:2011
- Timber moisture content must not exceed 18% (see p.34)
- If required nogs to be evenly spaced with a maximum spacing of 1350mm. If staggering nogs off a centreline it is recommended a maximum offset of 50mm–75mm
- Nogs are not required behind the horizontal joint except in shower situations and specific fire, noise or impact prone area, such as stairwells or doorways

Fasteners

- 10mm GIB® plasterboard, minimum 25mm x 6g GIB® Grabber® high thread screws*
- 13mm GIB® plasterboard, minimum 32mm x 6g GIB® Grabber® high thread screws*

Installation

- 300mm max to top and bottom plates and perimeter studs

- Pairs of single fasteners to each stud where horizontal joint crosses
- Place fasteners no closer than 12mm from paper bound sheet edge or 18mm from any cut edge
- Fasteners at wall corners to be placed 50mm max in from the corner in each direction
- Do not place GIBFix® adhesive at sheet edges or within 200mm of fasteners
- Place daubs of GIBFix® adhesive 300mm max centres to intermediate studs
- Sheet edges at door or window openings can be adhesive fixed unless forming part of the perimeter of a bracing element
- Butt joints to be on framing or back-blocked
- Fasteners to be positioned no closer than 25mm from each other

Stopping

- Refer to the Jointing and Finishing section (p.86)

*Some GIB® Performance Systems may require different fastener lengths and types. Refer to the applicable GIB® System literature for more information.

Timber Frame – Horizontally Fixed

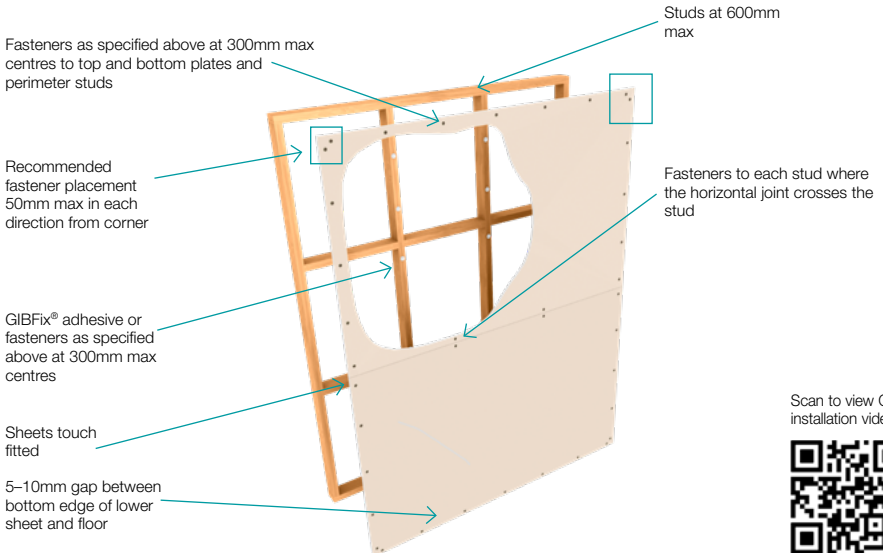

Scan to view GIB® installation videos



5.3 GIB® PLASTERBOARD INSTALLATION – WALLS

For installation guidance on GIB EzyBrace® and GIB Aqualine® Wet Area Systems refer to the GIB® Performance Systems section.

For all other GIB® Performance Systems refer to the relevant GIB® systems literature.

5.3.2 Timber Frame – Vertically Fixed

Wall Framing

- Framing dimensions, spacings and nog requirements must comply with NZS3604:2011
- Timber moisture content must not exceed 18% (see p.34)

Fasteners

- 10mm GIB® plasterboard, minimum 25mm x 6g GIB® Grabber® high thread screws*
- 13mm GIB® plasterboard, minimum 32mm x 6g GIB® Grabber® high thread screws*

Installation

- 300mm max centres around sheet perimeter
- Place fasteners no closer than 12mm from paper bound sheet edge or 18mm from any cut edge
- Fasteners at wall corners to be placed 50mm max in from the corner in each direction
- Do not place GIBFix® adhesive at sheet edges or within 200mm of fasteners
- Place daubs of GIBFix® adhesive 300mm max centres to intermediate studs
- Sheet edges at door or window openings can be adhesive fixed unless forming part of the perimeter of a bracing element
- Butt joints to be on framing or back-blocked
- Fasteners to be positioned no closer than 25mm from each other

Stopping

- Refer to the Jointing and Finishing section (p.86)

*Some GIB® Performance Systems may require different fastener lengths and types. Refer to the applicable GIB® System literature for more information.

Timber Frame – Vertically Fixed

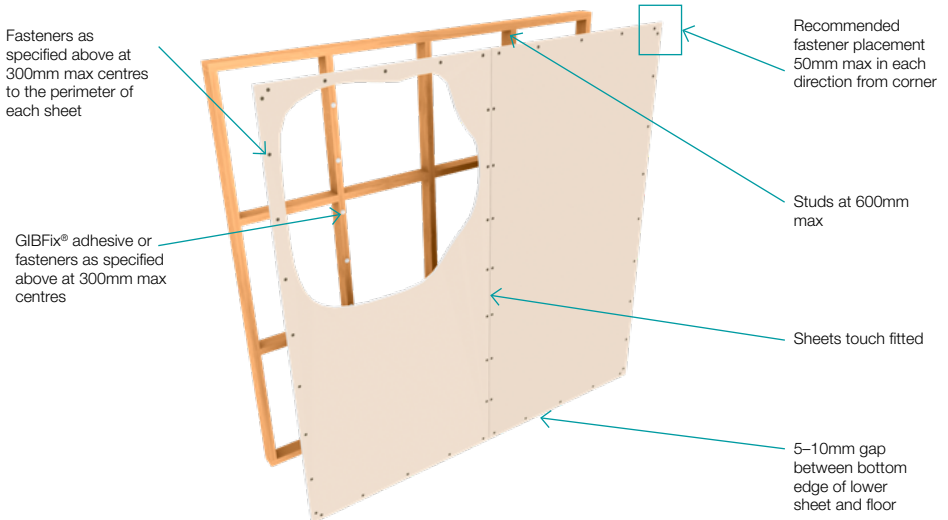

5.3 GIB® PLASTERBOARD INSTALLATION – WALLS

For installation guidance on GIB EzyBrace® and GIB Aqualine® Wet Area Systems refer to the GIB® Performance Systems section.

For all other GIB® Performance Systems refer to the relevant GIB® systems literature.

5.3.3 Steel Frame – Horizontally Fixed

Metal framing to which GIB® plasterboard is fixed must be in accordance with AS/NZS 4600 or NASH Standard. The lining thickness for specific design steel framing systems can be determined by the designer as a component in the system.

For other light steel framing application a minimum thickness of 13mm GIB® plasterboard must be used.

Wall Framing

- Steel stud dimensions to be min. 64 x 34 x 0.50mm nominal with a 6mm return
- Steel channel dimensions to be min. 64 x 30 x 0.50mm nominal
- Studs must be spaced at 600mm centres maximum
- Ensure that the studs are placed with the open side facing in the same direction (see diagram p.45)

Fasteners

- 13mm GIB® plasterboard, minimum 25mm x 6g GIB® Grabber® fine thread self tapping screws*

Installation

- 300mm max to top and bottom channels and end studs
- Pairs of single fasteners to each stud where horizontal joint crosses
- Place fasteners no closer than 12mm from paper bound sheet edge or 18mm from any cut edge
- It is recommended that fasteners at wall corners be placed 50mm max in from the corner in each direction
- Do not place GIBFix® adhesive at sheet edges or within 200mm of fasteners
- Place daubs of GIBFix® adhesive at 300mm max centres to intermediate studs
- Sheet edges at door or window openings can be adhesive fixed unless forming part of the perimeter of a bracing element
- Butt joints to be on framing or back-blocked
- Fasteners to be positioned no closer than 25mm from each other

Stopping

- Refer to the Jointing and Finishing section (p.86)

*Some GIB® Performance Systems may require different fastener lengths and types. Refer to the applicable GIB® System literature for more information.

Steel Frame – Horizontally Fixed

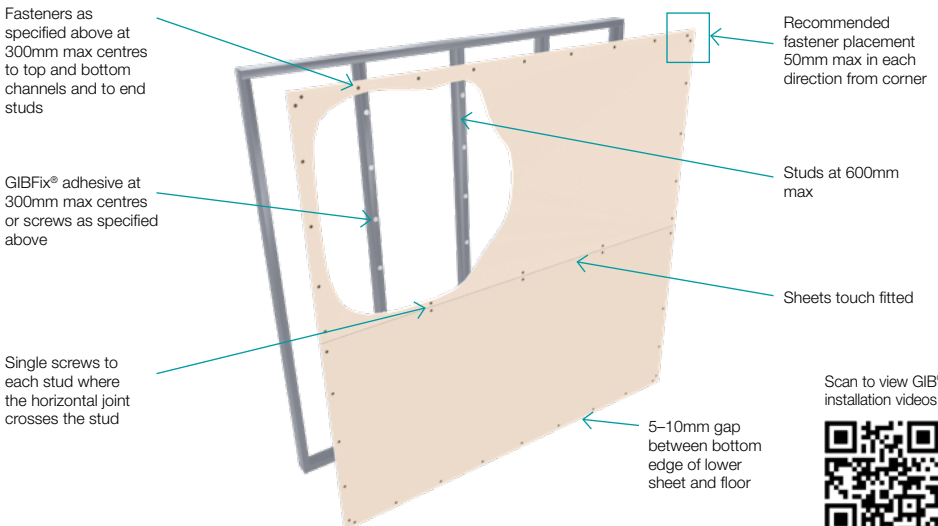

5.3 GIB® PLASTERBOARD INSTALLATION – WALLS

For installation guidance on GIB EzyBrace® and GIB Aqualine® Wet Area Systems refer to the GIB® Performance Systems section.

For all other GIB® Performance Systems refer to the relevant GIB® systems literature.

5.3.4 Steel Frame – Vertically Fixed

Metal framing to which GIB® plasterboard is fixed must be in accordance with AS/NZS 4600 or NASH Standard. The lining thickness for specific design steel framing systems can be determined by the designer as a component in the system.

For other light steel framing application a minimum thickness of 13mm GIB® plasterboard must be used.

Wall Framing

- Minimum steel stud dimensions to be min. 64 x 34 x 0.50mm nominal with a 6mm return
- Steel channel dimensions to be min. 64 x 30 x 0.50mm nominal
- Studs must be spaced at 600mm centres maximum
- Ensure that the studs are placed with the open side facing in the same direction (see diagram p.45)

Fasteners

- 13mm GIB® plasterboard, minimum 25mm x 6g GIB® Grabber® fine thread screws*

Installation

- 300mm max to centres around sheet perimeter
- Place fasteners no closer than 12mm from paper bound sheet edge or 18mm from any cut edge
- It is recommended that fasteners at wall corners be placed 50mm max from the corner in each direction
- Do not place GIBFix® adhesive at sheet edges or within 200mm of fasteners
- Place daubs of GIBFix® adhesive at 300mm max centres to intermediate studs
- Sheet edges at door or window openings can be adhesive fixed unless forming part of the perimeter of a bracing element
- Butt joints to be on framing or back-blocked
- Fasteners to be positioned no closer than 25mm from each other

Stopping

- Refer to the Jointing and Finishing section (p.86)

*Some GIB® Performance Systems may require different fastener lengths and types. Refer to the applicable GIB® System literature for more information.

Steel Frame – Vertically Fixed

Fasteners as specified above at 300mm max centres to the perimeter of each sheet

GIBFix® adhesive or screws at 300mm max centres

Commence fixing from the open side of the studs (studs must be placed with the open side facing the same direction)
See p.45

Stagger the sheet joints 600mm from those on the other side of the wall

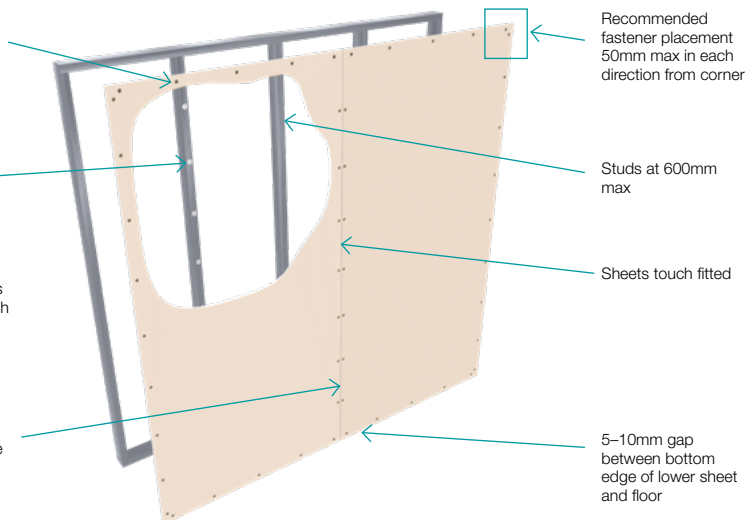

5.3.5 Fastening to Metal Studs

Correct Method

As the face of a steel stud can deflect initially, the correct sequence of attaching the plasterboard is important. The first sheet is attached to the open side of the stud which will cause minor deflection but will pull back tight against the sheet when the screw is fully tightened.

When the second sheet is fixed there will be minimal deflection as the open flange is now supported by the previous sheet.

Support the stud to avoid twisting.

Fastening GIB® Plasterboard to Metal Studs

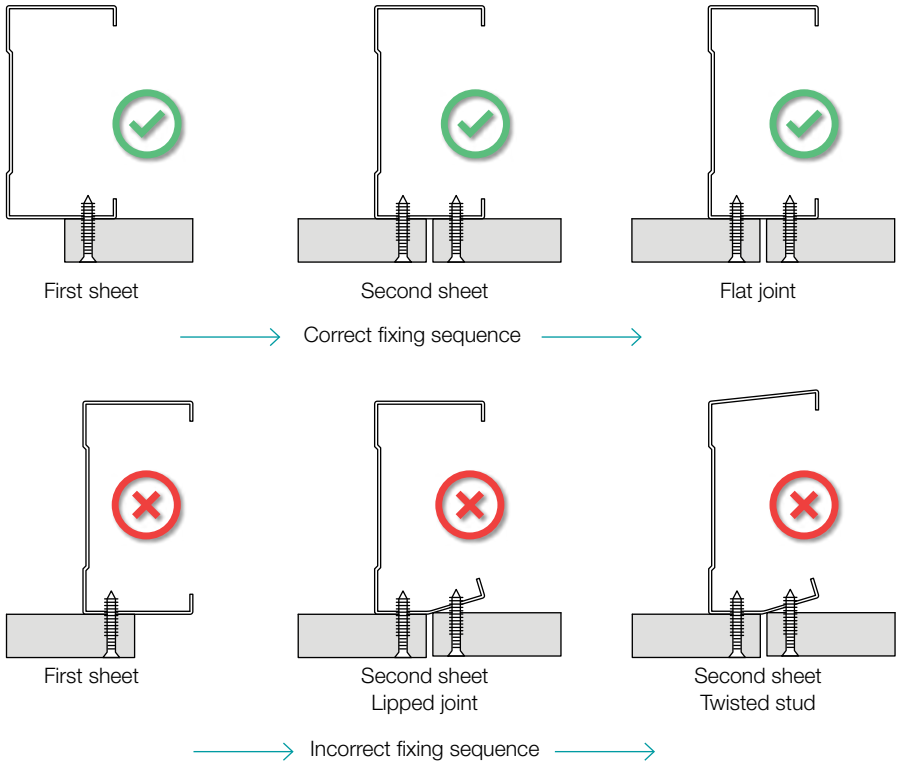

Incorrect fixing method can result in lipped joints, twisted studs and misalignment of the wall.

Scan to view GIB® installation videos



5.3.6 Grooved Jambs and Architraves

Architraves make best practice fixing of plasterboard much simpler. If the use of grooved jambs is unavoidable here is some information to help minimise plasterboard fixing problems.

Grooved door jambs and window liners are an integral part of the New Zealand building scene. Their use means that additional joints may need to be used. Installation of grooved jambs is subject to workmanship skills. Unless the jambs are correctly set up and installed, with a 1–2mm clearance for the plasterboard, it is difficult to install the plasterboard effectively.

When using grooved jambs the following rules should be followed.

The groove must be at least 1–2mm wider than the board that is being used.

Trying to get a 10mm plasterboard into a 10mm groove will be difficult.

Line the back of the groove up with the face of the substrate.



Correct installation of grooved jambs using an 11–12mm packer.

Grooved Jambs and Architraves

Summary

- Grooved jambs are designed to be quick and easy to install. Unless they are installed correctly, they can cause delays in plasterboard fixing and remedial work due to poorly positioned joints
- Unless a small amount of time and effort is invested in getting the unit set up correctly, grooved jambs and liners can cause far more problems than they are worth
- Simple best practice carpentry techniques are all that is required to install units accurately
 - Accurate measuring and ordering by the building contractor
 - Accurate fabrication by the joinery manufacturer
 - Careful installation by the installer

Architraves Option

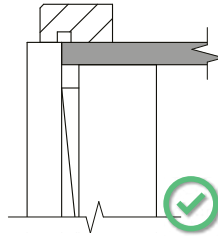

Recommended

Grooved Jamb Option

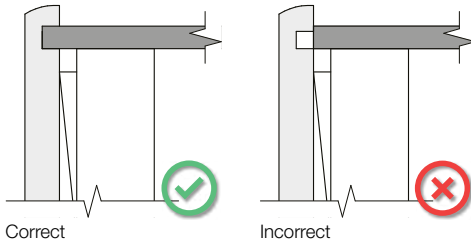

DO NOT place the tapered edge of a sheet into the groove. This requires unnecessary additional stopping.

5.3.7 Reducing Joints When Using Grooved Jambes

- Line the wall with the opening before lining any adjacent walls
- Joinery must be accurately installed to give 1.5–2mm clearance for sheet into the groove (see p.46)
- Groove depth should be 8mm minimum
- Cut lower sheet 20mm less than overall wall length
- Measure from wall or floor to outer edge of joinery frame (not into groove)
- Cut lower sheet as shown in Fig. 2
- Install sheet by placing against the wall and sliding and lifting into grooves as required

- Repeat the procedure for the upper sheet. Measure D from the top edge of the fixed lower sheet to the top outer edge of the window frame. Deduct 6mm from this measurement

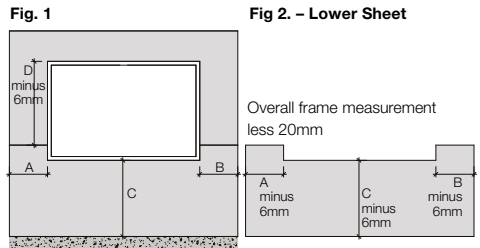

5.4 INSTALLATION TO CEILINGS

5.4.1 General Installation

Truss dimensions and spacings must comply with NZS3604:2011.

The use of GIB® Rondo® metal ceiling battens is strongly recommended. Timber battens can be prone to conditions that contribute to joint failure and popped fasteners. If using timber ceiling battens, additional care needs to be taken to ensure that the moisture content is 18% or less. (see p.34)

To limit sag, loads on GIB® plasterboard ceilings must not exceed an insulation weight of 4.2kg/m², and a fixture weight of 1kg or more unless they are independently supported. The placement of ceiling fixtures such as light fittings are to be limited to one fixture per m² unless independently supported.

Winstone Wallboards recommends:

- 13mm GIB® plasterboard on GIB® Rondo® steel battens at 600mm max centres
- Ceiling battens are installed after the roof framing is complete and the roof has been loaded
- All ceiling sheets be fixed at right angles to the ceiling framing. Sheets must not be fixed in the same direction as the framing to which it is attached. All ceiling battens in a single area need to run in the same direction to enable this. Sometimes this will require additional nogs to be fitted between trusses. Failure to do this will result in a tapered edge/cut edge joint at a point that is highly susceptible to cracking

General Ceiling Installation



Additional nogs may be required in this area

Recommended

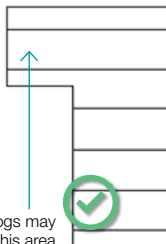

Not Recommended

- more prone to cracking

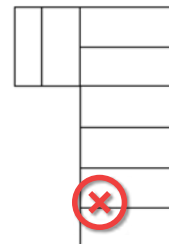

Scan to view GIB® installation videos



5.4.2 Standard Ceiling Fixing

This information applies to the general installation of GIB® plasterboard. If bracing, fire or noise control is a consideration consult the relevant GIB® Systems literature.

Ceiling Framing

- If using timber ceiling battens, timber moisture content must not exceed 18% prior to lining (see p.34)
- Battens should all run in the same direction within a ceiling area. Additional noggs may be required to achieve this

Batten Spacing

- 10mm GIB® plasterboard – 450mm maximum
- 13mm GIB® plasterboard – 600mm maximum
- Winstone Wallboards recommends the use of 13mm GIB® plasterboard in ceiling applications for optimal performance

Fasteners

Metal Battens

- Minimum 25mm x 6g GIB® Grabber® fine thread self tapping screws*

Timber Battens

- Minimum 32mm x 6g GIB® Grabber® high thread screws*

Fastener Spacings

- Single screws at the edges and centre of the sheet across the batten
- Single screw at 600mm max to the perimeter of the ceiling. See p.74 for ceiling diaphragm installation
- Place fasteners no closer than 12mm from a taper sheet edge or 18mm from a cut sheet edge

Adhesive

- Place daubs of GIBFix® adhesive at max 200mm to intermediaries
- Do not place adhesive at sheet edges or within 200mm of fasteners

Lining

- Sheets should be touch fitted
- Sheets must be fixed at right angles to the ceiling framing unless otherwise specified in GIB® Performance System specifications

Stopping

- Refer to the Joint and Finishing section (p.86)

*Some GIB® Performance Systems may require different fastener lengths and types. Refer to the applicable GIB® System literature for more information

Ceilings

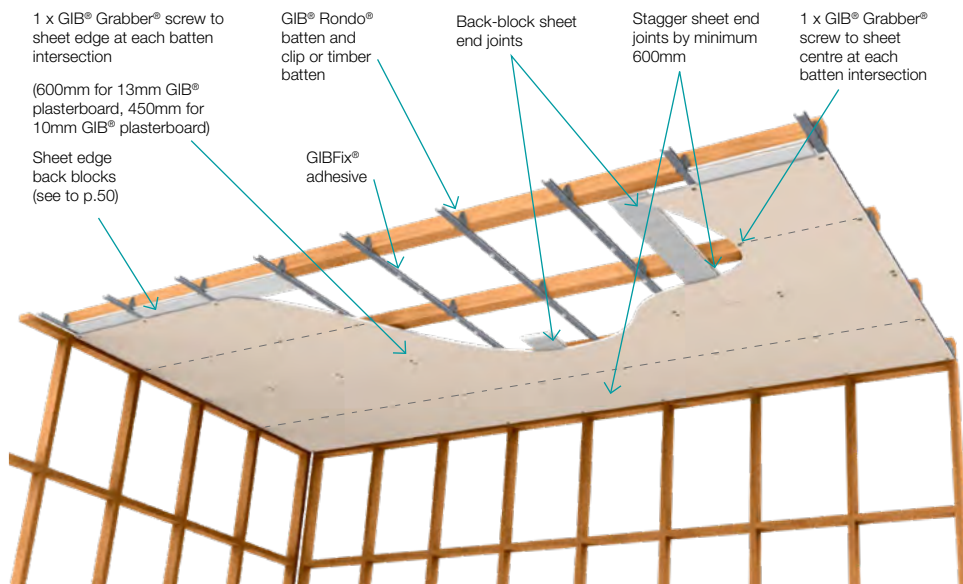

5.4.3 Raking Ceilings and Skillion Roofs

Due to the higher temperatures and low air movement that can occur in raking ceilings it is strongly recommended that clip fixed GIB® Rondo® metal battens are used (these are considered to be ceiling suspension systems).

Because of the heat that can be generated in roof spaces, timber battens can be subjected to conditions that contribute to joint failure and popped fasteners.

The use of control joints or perimeter relief will help reduce the risk of cracking in large, expansive ceilings.

These may not be suitable for use in Fire or Noise Control Systems.

Back blocking of all ceiling joints is highly recommended as it can reduce the likelihood of cracking.

Fixed – Steel Backing Angle

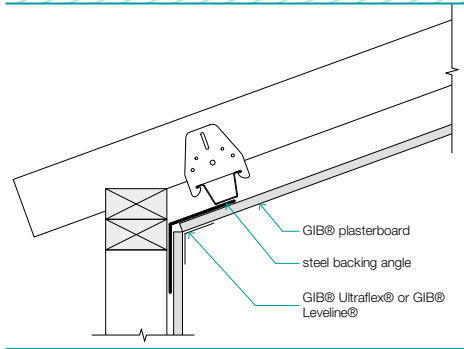

Flexible – Perimeter Relief

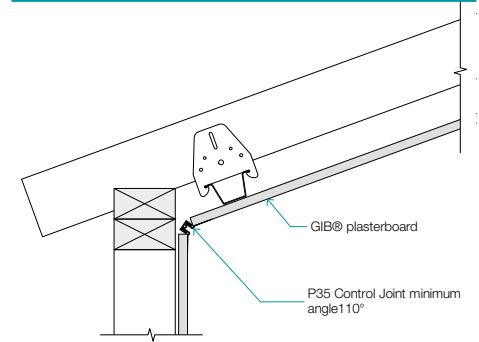
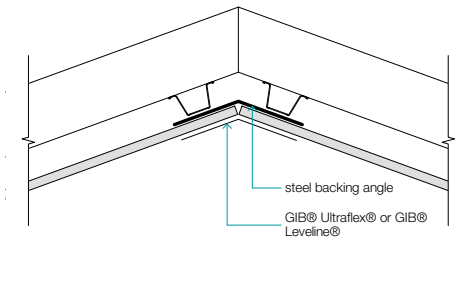
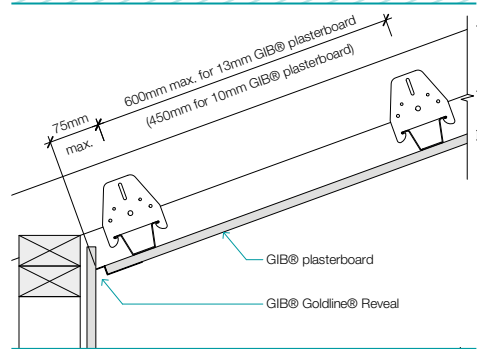

Note: It is recommended that a flexible perimeter relief be used where there is a high risk of movement.

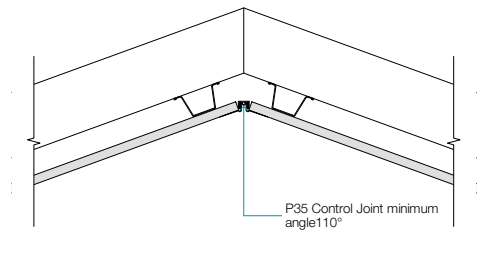

5.4.4 Back Blocking – Butt and Edge Joints

Back blocking is the practice of laminating an off-cut of plasterboard to the back of a joint using GIB-Cove® Bond adhesive.

Back blocking is required to ceiling sheet edge joints as follows:

Timber Battens	When there are 3 or more tapered edge joints in a ceiling area
Metal Battens	When there are 6 or more tapered edge joints in a ceiling area

Back blocking is required to all joints when a Level 5 Finish has been specified.

Back blocking is strongly recommended at sheet end joints in ceilings. Some fire rated systems require that joints are made on solid blocking and that requirement takes precedence and must be followed. Refer to GIB® Fire Rated Systems specifications for more information.

Back blocking is not required for a Level 4 Finish when a suspension system has been used. This includes GIB® Rondo® metal ceiling batten system fixed on clips. See p.49. Sheets ends should be back blocked.

Due to wind pressure when garage door is open, and vibration from garage door opening, it is recommended that all sheet joints in garage ceilings are back blocked.

Back Blocking Comprises 2 Steps:

- Laminating a piece of plasterboard to the back of the joint
- Forming a tapered edge to help form a flat stopped joint

Step 2 can be omitted but the stopped joint will need to be much wider (500–600mm) in order to minimise the effect of the stopped joint thickness.

Back Blocking Technique

- Make back blocks at least 300mm wide and cut to fit loosely between framing members
- Apply GIB-Cove® Bond to the underside of the back block with a 6–8mm notched trowel
- Do not use synthetic wall board adhesive for back blocking
- If possible, attach the back block to the back of the joint from above
- If access from above is not possible, apply GIB-Cove® Bond to one half of the back block before attaching the back block to the edge of the sheet. Install a couple of screws through the tapered edge to secure the back block
- Apply GIB-Cove® Bond to the remainder of the back block just before fixing the next sheet

Back Blocking

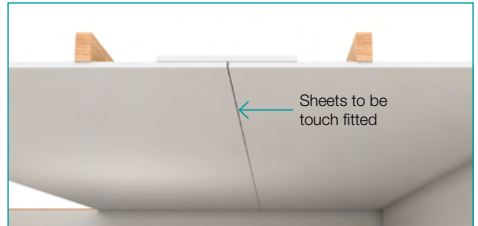
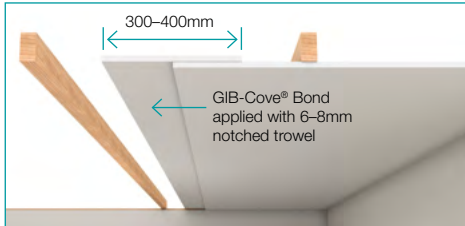

Creating a Tapered Edge

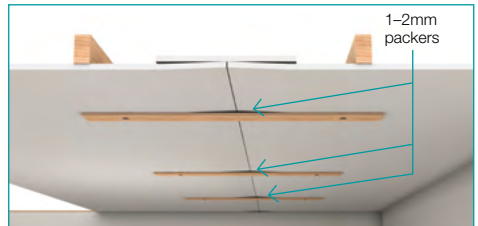

5.4.5 Control Joints – Walls and Ceilings

Control joints relieve stress due to movement of dissimilar materials when subjected to change in temperature and humidity. The joint positions are designed to accommodate such minor movements but do not allow for significant timber drying shrinkage or structural deformations such as may result from high wind or earthquake forces.

Walls

- In long unbroken partitions or wall runs, control joints are required at maximum 12 metre centres in either direction*
- They are also required where structural control joints occur in the primary structure
- Door frames extending from floor to ceiling constitute effective control joints in either direction*

Ceilings

- Extensive ceiling areas must have control joints spaced at maximum 12 metre centres in either direction*
- It is recommended joints be positioned to intersect lighting fixtures, heating vents or air diffusers or at junctions of corridors with open areas

Other situations

- Where GIB® plasterboard meets dissimilar materials, it is recommended to isolate using an edge trim, casing bead or control joint
- Control joints may also be required to match other building movement joints and closer spacing may be required to provide seismic relief and minimise the risk of lining damage following an earthquake (check with building designers)

- Special detailing is required where control joints are detailed in GIB® performance systems such as fire rated, bracing or noise control systems or a ceiling diaphragm (for further information phone the GIB® Helpline 0800 100 442)
- In stair wells and high timber framed walls, provision can be made for timber movement by installing a control joint or alternatively leaving a 20mm gap between the plasterboard sheets at the midfloor. This gap may be covered by a suitable cover batten

*Reference AS/NZS 2589: 2017- 3.4

Maximum Centres	Joint Control
12 metres	Walls
12 metres	Ceilings

Perimeter relief using GIB® Goldline® Tape-On Trims

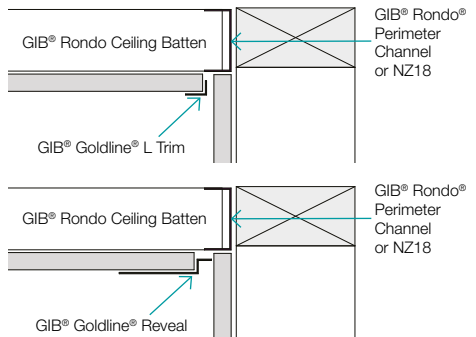

Control Joints in Ceilings – Recommendations to Reduce Risk of Cracking

There are some common places within the 12m spacing where cracks are most likely to occur in ceilings (as shown below). It is recommended to consider installing control joints in these locations (as shown below) to reduce the risk of cracking.

Where hallways exit from a larger ceiling area.	At internal corners in irregular shaped ceilings or where the main ceiling would look better divided into smaller sections.	At openings such as skylights, voids or recessed strip lighting. This may also include designated functional areas of a space.
Plan view 	Plan view 	Plan view

5.4.6 Control Joint Installation Details

GIB® Rondo® P35 control joint

- Allow an 18mm minimum gap between the plasterboard sheets
- Locate the GIB® Rondo® P35 control joint centrally in the gap. Staple both flanges to the lining at 150mm centres maximum
- Finish with jointing compound using the channel ribs as screeding guides
- When the joint is dry remove the protective tape

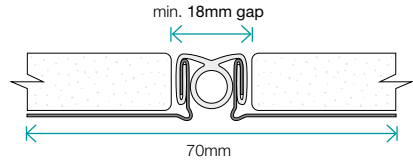

Control joint using GIB® Goldline® Platinum trim

- Allow a 14–17mm gap between the plasterboard sheets
- Install GIB® Goldline® Platinum GR reveal to one side of joint
- Install GIB® Goldline® L-Trim to the other side. Use a spacer to provide an even gap between the trim. This can be between 3–12mm
- Apply compounds as described on p.91-92

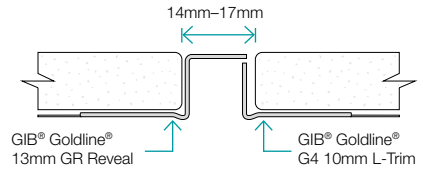

GIB® Plastic W-profile Control Joint

- Discrete finish and has tear-away tabs for easy installation
- This trim is thicker than the other control joint trims and thus may have implications for the final joint height
- Available in 3.0m lengths

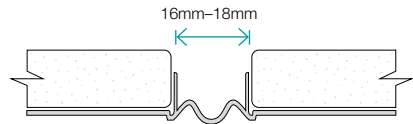

Note: Contact the GIB® Helpline 0800 100 442 for detailing of control joints in GIB® Performance Systems (e.g. fire, noise, bracing).

GIB® Rondo® Steel Battens

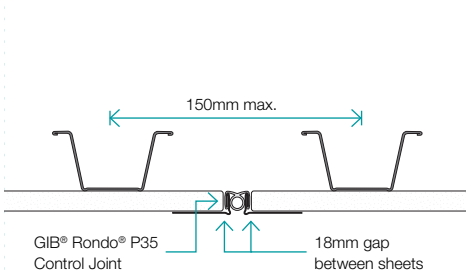

Timber Stud Walls

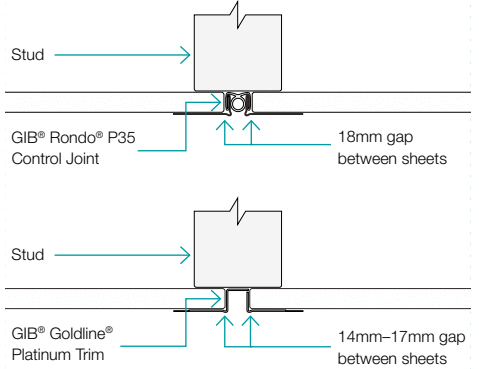

Two Storey Full Height Wall with Expansion Joint

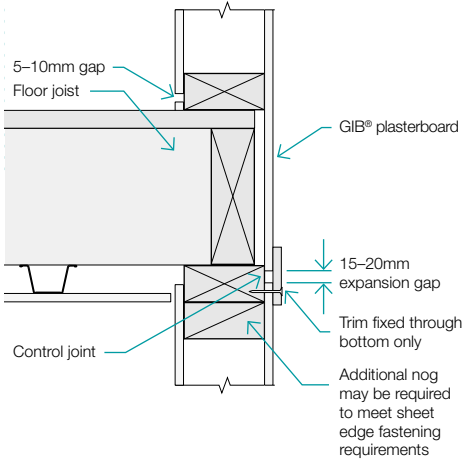

Masonry Junction Timber or Steel Framing

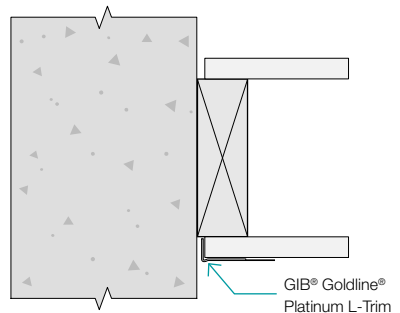

Where control joints are to be used in GIB® Fire Rated Systems refer to the GIB® Fire Rated Systems Manual for technical guidance.



5.4.7 GIB® Rondo® 310 Metal Batten System Installation Instructions

The GIB® Rondo® 310 system forms a strong, stable and flat substrate for ceilings in residential and commercial applications. The 35mm dimension allows it to be directly substituted into ceilings where 35mm timber battens would traditionally have been used. Consult an electrical contractor for any earthing requirements that may need to be incorporated.

There are two methods of fixing GIB® Rondo® 310 metal battens.

Recommended method

Clipped using either:

- 311D clip for a drop of 0–30mm
- 313 clip where a larger drop is required between the bottom of the truss chord, joist or rafter and the back of the ceiling batten. A drop of up to 130mm can be achieved in

order to accommodate services or variations in framing heights

- GIB Quiet Clip® in GIB Noise Control® Systems

Alternative method

- Directly by fastening with pairs of min. GIB® Grabber® 32mm x 8g wafer head screws through the flange
- Alternatively pairs of min. 45mm x 2.8mm flat head nails can be used
- For fixing to steel framing a drill tip screw is recommended

Note: If the 310 system is to be used in a ceiling diaphragm the batten needs to be screwed directly through the flanges to the framing.

See detail on p.75

GIB® Rondo® 310 System

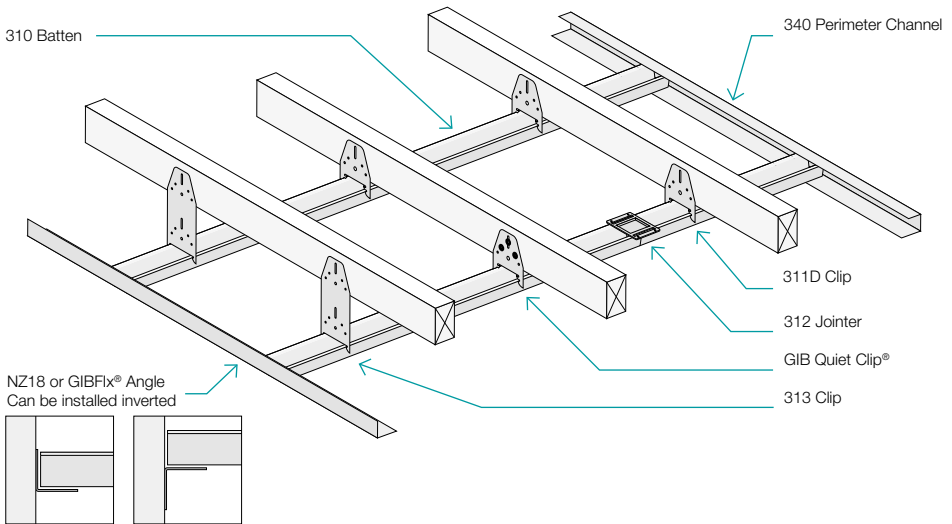

For ceiling diaphragm details refer to p.74

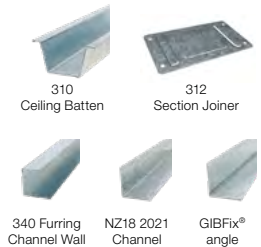
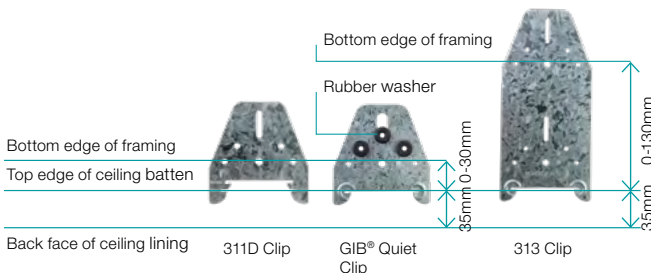

GIB® Rondo® 310 System

Recommended Best Practice Details

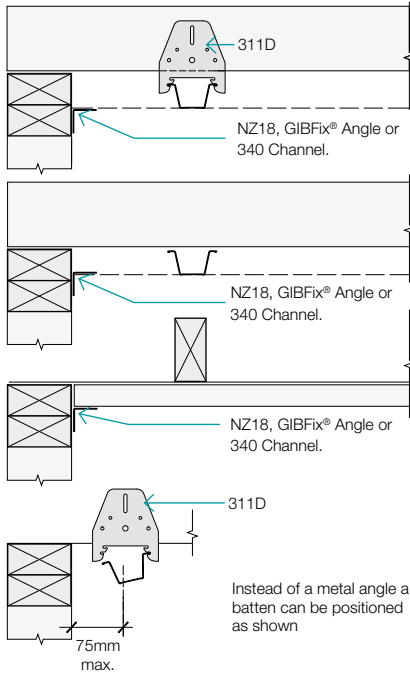

Other Details

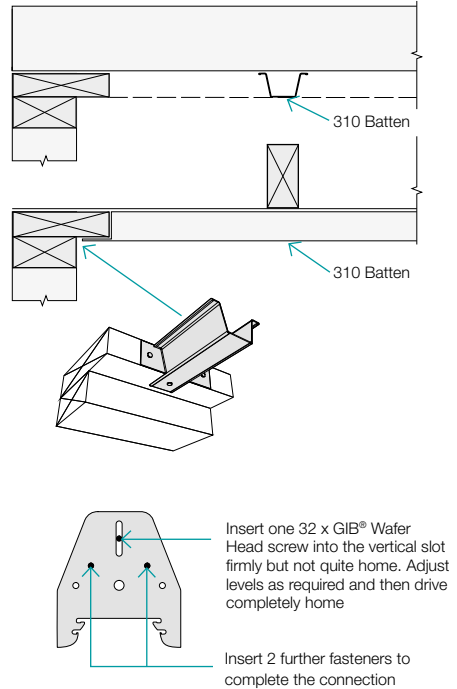

- Establish a datum line for the ceiling
- Place a string line on the datum line at right angles to the battens, under the truss or joist angles closest to the centre of the room
- Install GIB® Rondo® clips at 600mm centres (450mm for 10mm GIB® plasterboard) using the string line to establish the correct position

- Cut the batten to the required length using snips or a hacksaw
- Insert the batten into the channel at each end and fit into the clip
- Install remainder of clips ensuring that the batten is straight and flat

GIB® Rondo® 310 Batten Span Table for Residential Internal Applications

GIB® Plasterboard Thickness – Single layer	10mm	13mm
Maximum Batten Spacing (mm)	450	600
Multi Span (mm)	1200	
Single Span and Garages (mm)	900	

Battens

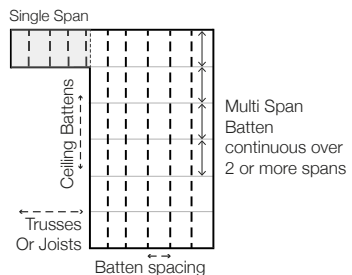



5.4.8 GIB® Rondo® 308 Metal Batten System Installation Instructions

The GIB® Rondo® 308 system is a lightweight yet very strong ceiling batten. In addition to its function as a ceiling batten it can also be used as a wall furring channel and is an integral part of GIB Noise Control® Systems for walls. Consult an electrical contractor for any earthing requirements that may need to be incorporated.

Recommended Method

The GIB® Rondo® 308 system is installed using either:

- 226 clip for a drop of 0–30mm
- 394 clip where a larger drop is required between the bottom of the truss chord, joist or rafter and the back of the ceiling batten. Up to 130mm clearance between the bottom of the framing and the back of the batten of can be achieved in order to accommodate services or variations in framing heights

Note: If the 308 system is to be used in a ceiling diaphragm, the batten needs to be secured directly to the framing (see p.75).

GIB® Rondo® 308 System

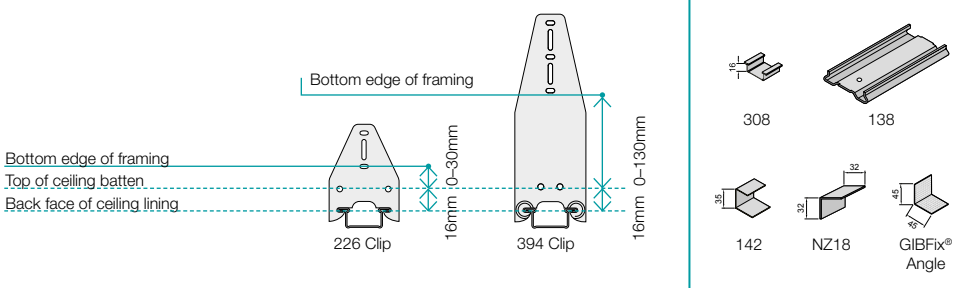
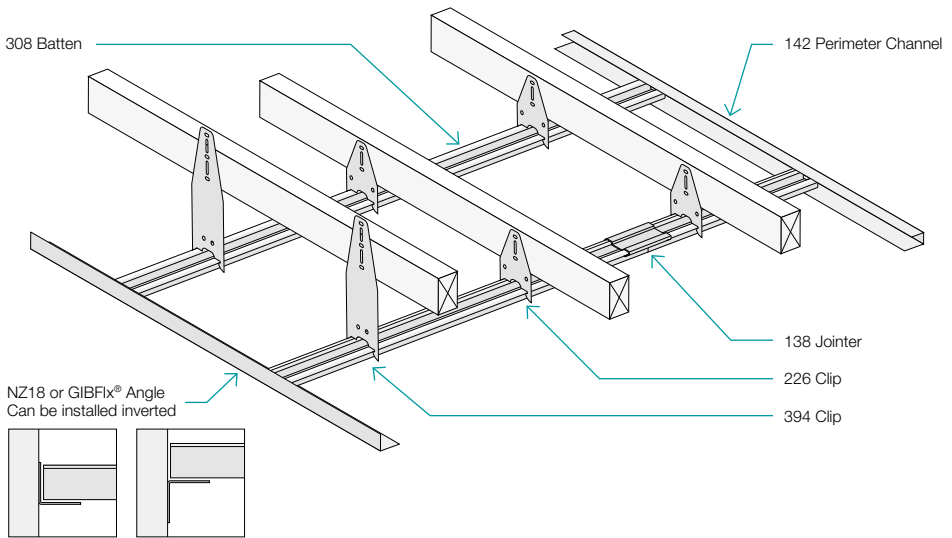

GIB® Rondo® 308 System

Recommended Best Practice Details

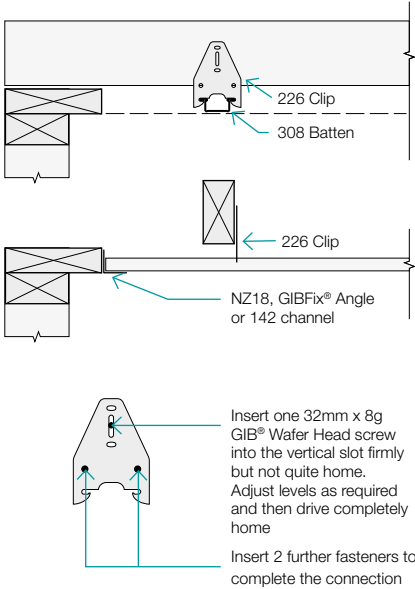

Other Details

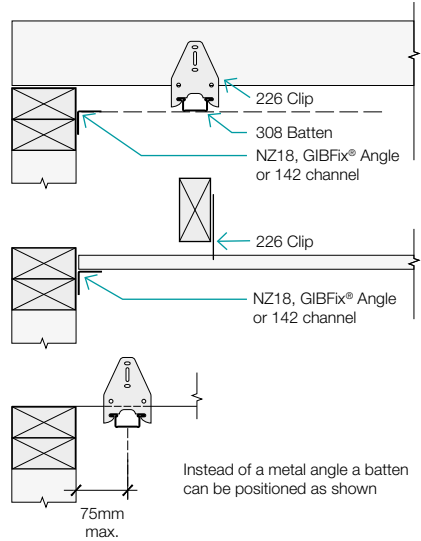

- Establish a datum line for the ceiling
- Place a string line on the datum line at right angles to the battens, under the truss or joist closest to the centre of the room
- Install GIB® Rondo® clips at 600mm centres (450mm for 10mm GIB® plasterboard) using the string line to establish the correct position

- Cut the batten to the required length using snips or a hacksaw
- Insert the batten into the channel at each end and fit into the clip
- Install remainder of clips ensuring that the batten is straight and flat

GIB® Rondo® 308 Batten Span Table for Residential Internal Applications

GIB® Plasterboard Thickness – Single layer	10mm	13mm
Maximum Batten Spacing (mm)	450	600
Multi Span (mm)	1200	
Single Span and Garages (mm)	900	

Battens

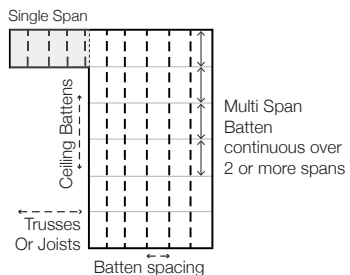



5.4.9 GIB® Rondo® Suspended Ceiling System

The range of GIB® Rondo® suspended ceiling componentry provides additional clearance above the ceiling level. This could be to run electrical, plumbing or ventilation equipment. The system allows for the ceiling lining material to be directly attached to the lower face of the battens.

This is not to be confused with a two way grid system which accommodates proprietary ceiling tiles. The components can be assembled in a wide range of combinations to suit a variety of applications. Refer to GIB® Rondo® System literature for more information.

GIB® Rondo® Suspended Ceiling Components

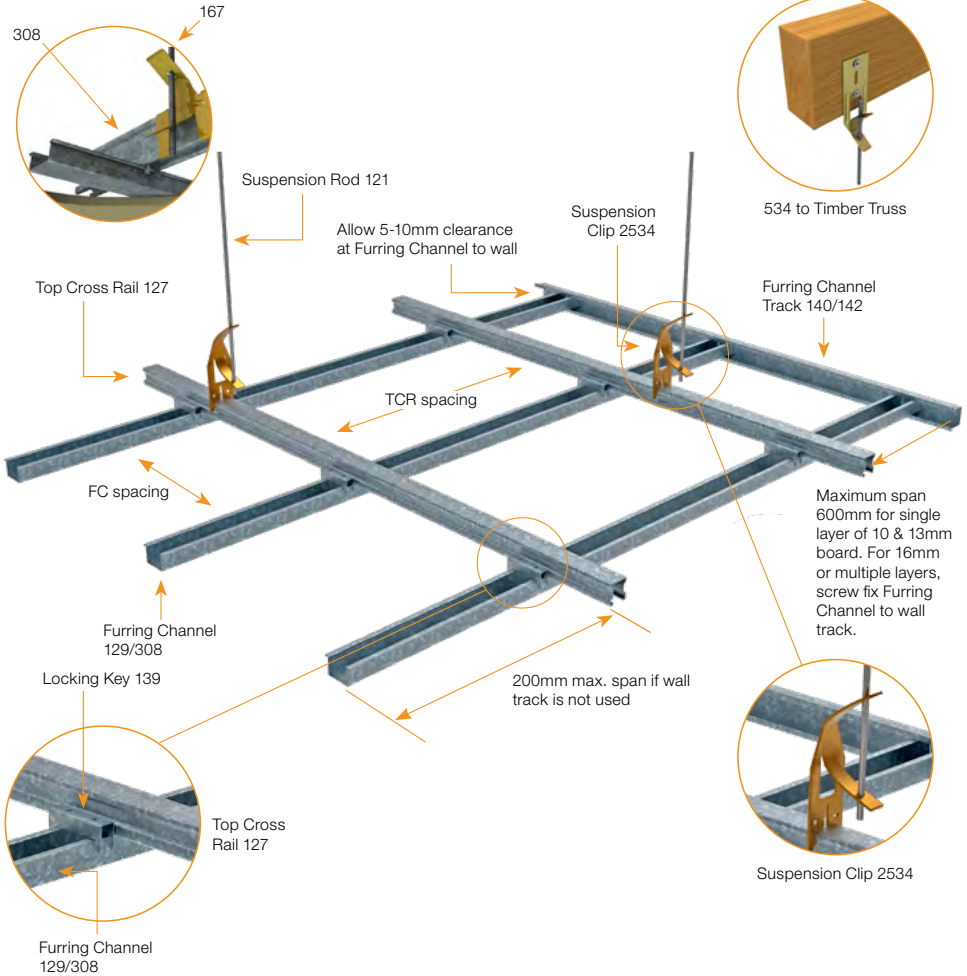

5.5 CURVING GIB® PLASTERBOARD

GIB® plasterboard can be curved. Curvature is dependent on the thickness and whether the board is applied wet or dry.

The radii shown below are for:

GIB Standard, GIB Ultraline®, GIB Braceline®/Noiseline®, GIB Weatherline®, GIB Fyreline®, GIB Aqualine® and GIB X-Block®.

It is not recommended to curve thicker and some

high density boards such as 16mm and 19mm GIB Fyreline®, GIB Toughline®, GIB Toughline® Aqua and GIB Barrierline® due to the risk of breakage.

Curved walls can be incorporated into performance systems provided the curving is carried out strictly in accordance with the application method detailed below.

Minimum Bending Radii of GIB® Plasterboard

Board Thickness/ Type	Minimum Radius (Wet)*	Minimum Radius (Dry)
10mm GIB® Plasterboard**	1000mm	1200mm
13mm GIB® Plasterboard***	1200mm	1500mm

*Not applicable to GIB Weatherline® and GIB Aqualine®

**Includes 10mm GIB Weatherline®

***Includes 13mm GIB Weatherline® but excludes 13mm GIB Toughline® and GIB Toughline® Aqua

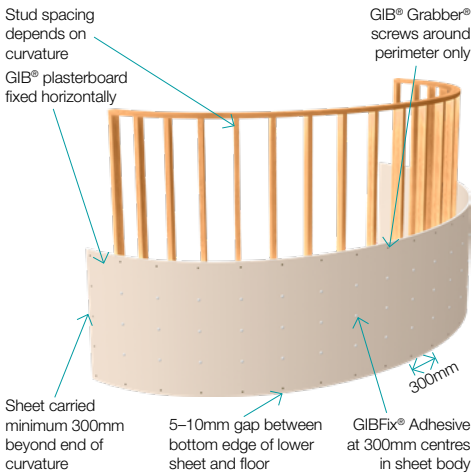

Application Method

- Ensure that framing spacings in the table above are correct
- Sheets must be fixed horizontally to walls
- If possible, select board length to allow for one unbroken panel to cover the entire curve with enough extra length to extend 300mm beyond each end
- When curving 'wet', apply water with a paint roller to both sides. Approximately 40 mL/m² of water and 10 minutes set time are required
- When creating an outside curve, begin installation at one end and fasten the sheet as it is wrapped around the curve

Framing Centres

Wall or Ceiling Radius	Maximum Stud, Batten or Joist Spacing
900mm - 1200mm	200mm
1200mm - 3000mm	300mm
3000mm - 4000mm	400mm
Over 4000mm	600mm (450mm for 10mm GIB® Plasterboard in ceiling applications)

The projection of a curved GIB EzyBrace® bracing element should be used as the effective wall length, as illustrated below.

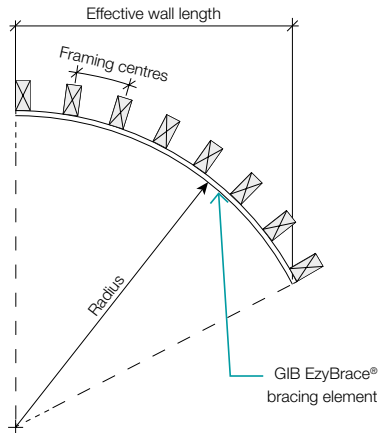

- When creating an inside curve, start fastening the sheet at the centre of the curve and work outwards to the end of the sheet

The development work found that curving GIB® plasterboard requires patience. Rushing the curving process can result in board breakages. Taking your time and allowing the board to take the curve is the best approach. The typical time taken to successfully fit a board to a curve is 30 - 40 minutes.

Note: Lining the inside of the curve will be more difficult than lining the outside. This will require additional labour and the GIB® plasterboard must be curved prior to installation.

5.6 FIXING TO MASONRY

Direct bonding of GIB® plasterboard to concrete or brick masonry walls must only be considered when the concrete or masonry substrate is thoroughly dry and adequately protected against moisture penetration.

The substrate must be firm, dry, and free of dust, grease, release agents and curing compounds.

In situations where dampness or rain penetration problems exist, corrective measures must be taken prior to installation of interior linings.

Movement and control joints in the main structure must be carried through the GIB® plasterboard linings. This can be achieved by installing a control joint in the plasterboard.

Direct Bonding (For Sheet Heights up to 3m)

- Determine the sheet position for either vertical or horizontal fixing and mark on wall
- GIB® plasterboard sheets can be fixed vertically or horizontally. Horizontal fixing creates fewer joints and is recommended
- Use GIB-Cove® Bond to bond the GIB® plasterboard to concrete or masonry surfaces
- Mix GIB-Cove® Bond to a smooth, thick consistency
- Apply GIB-Cove® Bond daubs approximately 50mm diameter x 12mm thick at 300–400mm centres vertically and 500–600mm centres horizontally. Ensure that adhesive is placed no closer than 25mm from the edge of the sheet
- Where irregularities up to 10mm occur on the masonry surface, use larger daubs of adhesive to bridge the gap
- Position the sheet and press into place
- Obtain true alignment and flatness by using a long straight edge over the surface of the sheet
- Alternatively, apply adhesive over the entire back surface of the sheet using a notched trowel
- Apply GIB-Cove® or GIB® Trims to wall and ceiling intersections
- Fix skirting and architrave with masonry nails or adhesive

Daubs approximately 50mm diam. x 12mm high

Daubs placed no closer than 25mm from sheet edge

Control joints in walls need to continue through GIB® plasterboard

GIB-Cove® Bond adhesive daubs at 300–400mm centres vertically and 500–600mm centres horizontally

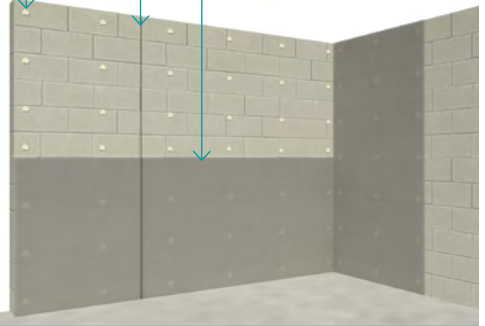

Wall Strapping must be used:

- Wall Strapping must be used:
 - When the concrete or masonry wall is below ground level
 - When the concrete or masonry wall is an external wall, unless a proprietary external weatherproofing system can be verified as providing weather tightness for the life of the building
 - In bathrooms, laundries and other wet areas
 - When the concrete or masonry substrate or paintwork is in poor condition
 - When the wall surface contains irregularities of more than 8–10mm strapping can be packed to provide a flat surface for the plasterboard
 - For walls in excess of 3.0m in height
- Use either nominally 50 x 25mm timber strapping or metal furring channels. Deeper strapping may be required to accommodate insulation requirements
- Fix DPC behind timber strapping
- Fix strapping vertically to the wall surface at a maximum of 600mm centres, with either a continuous horizontal batten or nogs at the top and bottom of the wall
- Install services prior to installing GIB® plasterboard linings

50 x 25mm KDMG timber or GIB® Rondo® Steel Battens, maximum 600mm apart.

Pack battens as required to provide a flat surface

For vertically fixed boards, use nogs between battens at 800mm centres

Nogs are not required for horizontally fixed boards



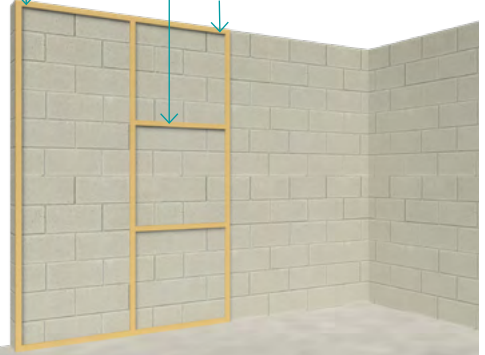

DPC behind timber strapping

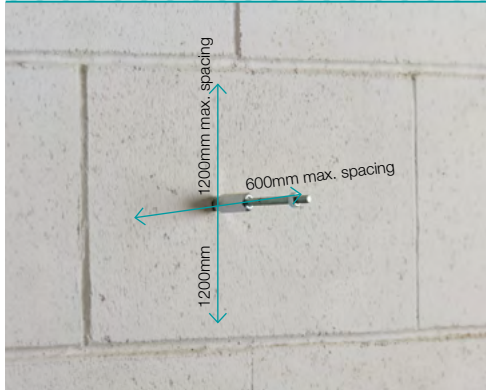

5.6 FIXING TO MASONRY

If insulation is required to concrete or masonry, it is recommended that GIB® Rondo® 308 battens are clipped to GIB® Rondo® A239 clips as

shown. A239 clips should be spaced at 1200mm centres (max) vertically and 600mm centres (max) horizontally.

<p>Anchor bolt</p> 	<p>Polystyrene</p> 
<p>A239 Clip</p> 	<p>308 Batten</p> 
<p>GIB® Plasterboard overlay</p> 